

International Standard Valve, Inc.

7111 Perimeter Park Drive, Bldg 320
Houston, Texas 77041
713-983-7600



QUALITY MANAGEMENT SYSTEM
CERTIFIED BY DNV
ISO 9001:2008

Two Piece Trunnion Mounted Ball Valve

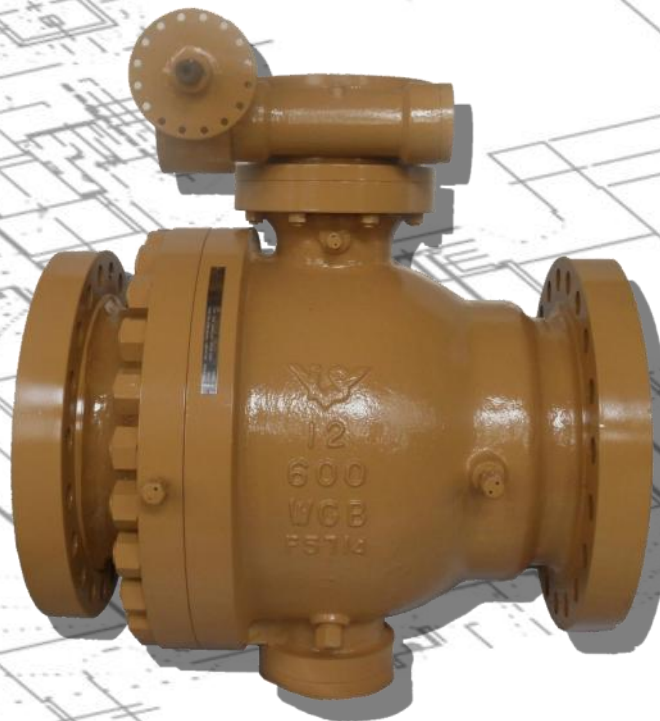

ASME
CLASS
150
through
1500

WCB
LCC
CF8M
Body

API 6D
Fire Safe
NACE
CE



is a registered trademark of International Standard Valve, Inc.

www.isvalve.com sales@isvalve.com

Bulletin No. ISV-SB210.6 Issue 02/2011

Specifying ISV Series No. BT3BF

2 PC trunnion ball valves

Example: ISV figure number **BT3B-F060-1210RF-DH-NFG**

Describes an ASME class 600, two piece bolted body design, full port, trunnion supported ball valve, raised face flange ends, with WCB body material, carbon steel + Electroless Nickel Plated trim, Devlon seats, HNBR seals, gear operated, meets NACE and is fire safe tested.

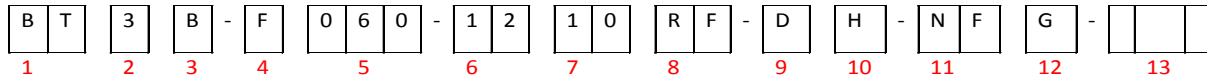

1. Valve Type		2. Service /Design Style		3. Body Design		4. Bore		5. Pressure Rating		6. Body Material	
Code	Description	Code	Description	Code	Description	Code	Description	Code	Class	Code	Description
BT	Ball Valve Trunnion	0	Adjustable Packing- (Commercial Design)	A	1 pc End Entry	R	Reduced	015	Class 150	11	A105N
BF	Ball Valve Floater	1	Adjustable Packing- Flanged(API 608, ASME B16.34)	B	2 pc Split- Bolted	F	Full	030	Class 300	12	WCB
		2	Adjustable Packing THRD,SW,NIPPLE,B W Ends (API 608, ASME B16.34)	C	2 pc Threaded	S	Standard Port	040	Class 400	21	A105N/LF2
		3	O-Ring Stem Seal	D	2 pc Seal Weld			060	Class 600	24	LCC
		4	Metal Seated Valve	E	3 pc Bolted			090	Class 900	36	CF8M
				F	3 pc Threaded			150	Class 1500	92	CS+ SS Seat Pocket
				G	3 pc Welded			250	Class 2500		
								450	Class 4500		

7. Trim Material		8. End Connections		9. Seat		10. Seal		11. Features		12. Operator	
Code	Description	Code	Description	Code	Description	Code	Description	Code	Description	Code	Description
10	C.S. + ENP	RF	Flg-RF	N	Nylon	V	Viton	NF	NACE compliant, Fire Safe Tested	L	Locking Lever
30	Stainless Steel	RJ	Flg-RTJ	T	PTFE	H	HNBR			B	Bare Stem
		FF	Flg-FF	D	Devlon	L	Low Temp. (-50 F.) O-Ring	NW	NACE compliant, Non-Fire Tested	A	Actuated
36	316SS / CF8M	WW	WE x WE	H	HNBR	9	PTFE-LIP SEAL			G	Manual Gear
		WF	RF x WE	R	R-PTFE	9	PTFE-LIP SEAL			H	Non-locking Lever
61	410 SS	WJ	RTJ x WE	C	TFM 4215	G	Graphite			C	Chain Wheel
				M	TFM 4105	T	PTFE	WF	Without NACE, Fire Safe Tested	O	Oval Hand wheel
				J	TFM 1600	M	TFM			S	Spring Return Lever
				V	Viton	E	EPDM				
				E	EPDM	F	Delrin	WW	Without NACE Non-Fire Tested		
				F	Delrin	K	Kel-F				

ISV Series No. BT3BF STANDARD FEATURES

Product Certifications	
API 6D	
API 607	
PED CE	

2-piece bolted body design.

Design meets API 6D, API 608 & ASME B16.34.

Manufactured, tested and monogrammed in accordance with API 6D.

Rugged polymeric seat material

Each valve is uniquely serialized for enhanced traceability.

Fire safe tested to API 607 5th Edition

ISV Series No. BT3BF Two Piece Construction Trunnion Mounted Ball Valves

Design Standards	
Basic Design	API 6D, API 608 ASME B16.34
Face to Face Dimension	ASME B16.10 API 6D
Flanged Ends	ASME B16.5
Pressure Test	API 6D

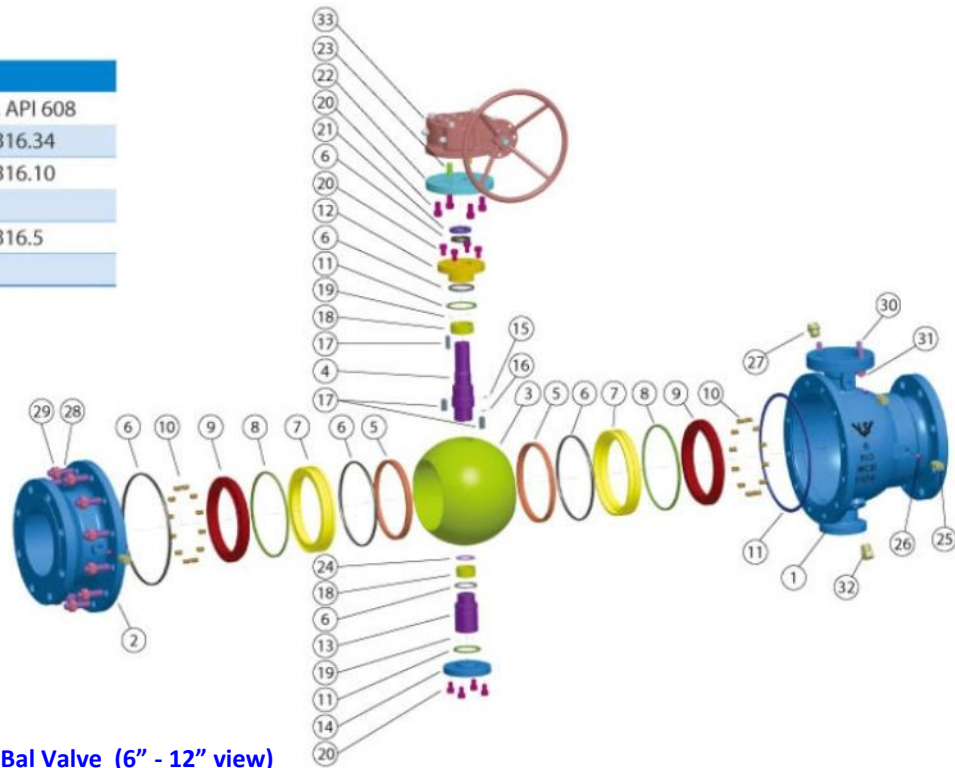

Material List of Trunnion Ball Valve (6" - 12" view)

No	Part Name	Materials		
1	Body	A216 WCB	A352 LCC	A351 CF8M
2	End Cap	A216 WCB	A352 LCC	A351 CF8M
3	Ball	A105N + ENP	Low temp A350 LF2 + ENP	A182 F316
4	Stem	AISI 1045 + ENP	Low temp. C.S. + ENP	17-4PH
5	Seat Insert ¹⁾	Devlon V ¹⁾ (Class 150 & 300: 15% glass filled PTFE)		
6	O-Ring	HNBR	Low temp. HNBR	HNBR
7	Seat Ring	A105N + ENP	A350 LF2 + ENP	A182 F316
8	Seat Gasket	Graphite		
9	Seat Pusher	A105N + ENP	A350 LF2 + ENP	A182 F316
10	Seat Spring	Inconel X-750		
11	Gasket	Graphite (Body-Cap Gasket is Graphite SPW ²⁾)		
12	Gland	A105N + ENP	A350 LF2 + ENP	A182 F316
13	Trunnion	A105N + ENP	A350 LF2 + ENP	A182 F316
14	Trunnion Cover ³⁾	A105N	A350 LF2	A182 F316
15	Anti-static ball	304SS		
16	Anti-static spring	304SS		
17	Stem Key	C.S.		
18	Bearing	C.S. + PTFE (DU)		S.S. + PTFE
19	Thrust Washer	S.S. + PTFE (DU) ⁴⁾		S.S. + PTFE ⁴⁾
20	Socket Cap Screw	A574 (eq. B7M)	A320 L7M	A193 B8
21	Fire Seal Packing	Graphite		
22	Top Plate	A105 + ENP		A182 F316
23	Pin	C.S.		
24	Ball Thrust Washer	PTFE ⁵⁾		
25	Grease Injection Fitting	Zinc plated carbon steel		316SS
26	Internal Check Valve	Zinc plated carbon steel		316SS
27	Vent Plug	Zinc plated carbon steel		316SS
28	Body Stud	A193 B7M	A320 L7M	A193 B8
29	Body Nut	A194 2HM	A194 4M	A194 8
30	Gear Stud	C.S.		
31	Gear Nut	C.S.		
32	Drain Valve	Zinc plated carbon steel		A276 316
33	Manual Gear	Commercial Carbon Steel		

- 1) Devlon is a registered trademark of the Devol Engineering company
- 2) 304SS Spiral wound graphite body gaskets
- 3) Applies only to 6" - 12" class 150 & class 300 valves
- 4) 2" - 4" class 150 & class 300 valves are equipped with PTFE bearings
- 5) 6" and larger valves are equipped with C.S. + PTFE (DU) bearings

ISV Series No. BT3BF Two Piece Construction Trunnion Mounted Ball Valves

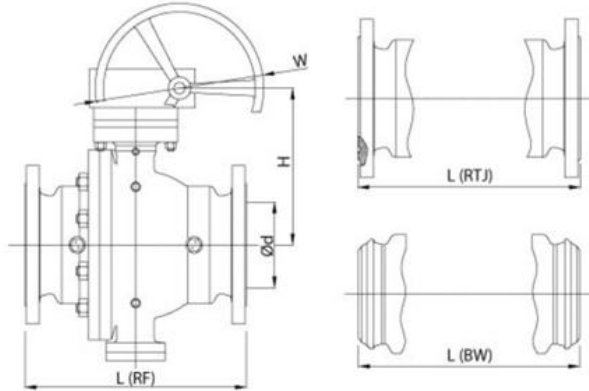

Working Pressures (psi)					
Class:	150	300	600	900	1500
O-ring Seals:	HNBR	HNBR	HNBR	HNBR	HNBR
Seats Inserts:	RPTFE	RPTFE	Devlon	Devlon	Devlon
Min. Temp: -20 deg. F.	285	740	1480	2220	3705
Max. Temp: 300 deg. F.	230	500	1250	1979 at 280 F	3320 at 260F

Pressure Test to API 6D (WCB body)			
	Shell Test (Hydrostatic)	Seat Test (Hydrostatic)	Seat Test (Air)
Class 150	450 psi	313 psi	80 psi
Class 300	1125 psi	814 psi	80 psi
Class 600	2225 psi	1628 psi	80 psi
Class 900	3350 psi	2442 psi	80 psi
Class 1500	5575 psi	4076 psi	80 psi

Dimensions and Weights

Valve Size:		NPS	2"	2 1/2"	3"	4"	6"	8"	10"	12"
Class 150	d	inch	2	2.5	3	4	6	8	10	12
	L (RF)	inch	7	7.5	8	9	15.5	18	21	24
	L (BW)	inch	8.5	9.5	11.13	12	18	20.5	22	25
	L (RTJ)	inch	7.5	8	8.5	9.5	16	18.5	21.5	24.5
	H	inch	6	6.5	7.63	8.4	10.9	12.6	15.56	18.13
	W (Gear Hand wheel)	inch					18	18	24	24
	WT (lbs)		RF	33	42	84	143	214	353	529
		BW	39	38	77	121	205	340	501	805
Class 300	d	inch	2	2.5	3	4	6	8	10	12
	L (RF)	inch	8.5	9.5	11.13	12	15.88	19.75	22.4	25.5
	L (BW)	inch	8.5	9.5	11.13	12	15.88	20.51	22	25
	L (RTJ)	inch	9.13	10.12	11.75	12.64	16.5	20.4	23	26.14
	H	inch	6	6.5	7.63	8.4	10.9	12.6	15.56	18.13
	W (Gear Hand wheel)	inch					18	18	24	24
	WT (lbs)		RF	40	60	104	176	260	441	805
		BW	31	49	84	143	232	408	754	1109
Class 600	d	inch	2	2.5	3	4	6	8	10	12
	L (RF)	inch	11.5	13	14	17	22	26	31	33
	L (BW)	inch	11.5	13	14	17	22	26	31	33
	L (RTJ)	inch	11.63	13.13	14.13	17.13	22.13	26.13	31.14	33.13
	H	inch	7	6.5	7.7	8.4	10.7	13.5	19.5	22.88
	W (Gear Hand wheel)	inch					18	18	24	24
	WT (lbs)		RF	84	125	146	269	479	772	1565
		BW	69	113	128	258	441	721	1301	1742
Class 900	d	inch	2	2 1/2	3	4	6	8	10	12
	L (RF)	inch	14.50	16.50	15.00	18.00	24.00	29.00	33.00	38.00
	L (BW)	inch	14.50	16.50	15.00	18.00	24.00	29.00	33.00	38.00
	L (RTJ)	inch	14.63	16.63	15.13	18.13	24.13	29.13	33.13	38.13
	H	inch	8.25	8.50	8.86	10.43	13.00	16.14	17.71	19.67
	W (Gear Hand wheel)	inch				18	18	24	24	24
	WT (lbs)		RF	106	132	172	304	747	1411	2117
		BW	99	117	165	289	582	1192	1764	2447
Class 1500	d	inch	2.00	2.50	3.00	4.00	5.75	7.67	—	—
	L (RF)	inch	14.50	16.50	18.50	21.50	27.75	32.75	—	—
	L (BW)	inch	14.50	16.50	18.50	21.50	27.75	32.75	—	—
	L (RTJ)	inch	14.63	16.63	18.63	21.63	28.00	33.13	—	—
	H	inch	7.75	8.70	10.00	11.44	14.00	17.67	—	—
	W (Gear Hand wheel)	inch			18.00	18.00	24.00	24.00	—	—
	WT (lbs)		RF	121	176	258	476	1173	1918	—
		BW	113	157	181	331	913	1493	—	—

