

STEAMCO

Fig. 128-A

Class 125 Iron Body Swing Check

Bolted Bonnet Horizontal Swing Bronze or All Iron Trim

From 2" to 12"

125 P S I 450 F
200 WOG -20 to 150 F

From 14" to 18"

100 P S I 450 F
150 WOG -20 to 150 F

Applicable Standards: MSS-SP-71, ANSI B16.1, ANSI B16.10

PARTS AND MATERIAL DESCRIPTION

| No. | Part | Material | ASTM Spec. |
|-----|------------|---------------|----------------|
| 1 | Body Bolt | Steel | ASTM A307 |
| 2 | Bolted Cap | Cast Iron | ASTM A126 Cl B |
| 3 | Gaskets | Non-Asbestos | Commercial |
| 4 | Hinge Pin | Forging Brass | ASTM B16 |
| 5 | Hinge | Cast Iron | ASTM A126 Cl B |
| 6 | Disk | Cast Iron | ASTM A126 Cl B |
| 7 | Disk Ring | Bronze | ASTM C83600 |
| | *Disk Ring | Cast Iron | ASTM A307 |
| 8 | Disk Bolt | Steel | ASTM A307 |
| 9 | Washer | Forging Brass | ASTM B16 |
| 10 | Seat Ring | Bronze | ASTM C83600 |
| | *Seat Ring | Cast Iron | ASTM A126 Cl B |
| 11 | Body | Cast Iron | ASTM A126 Cl B |

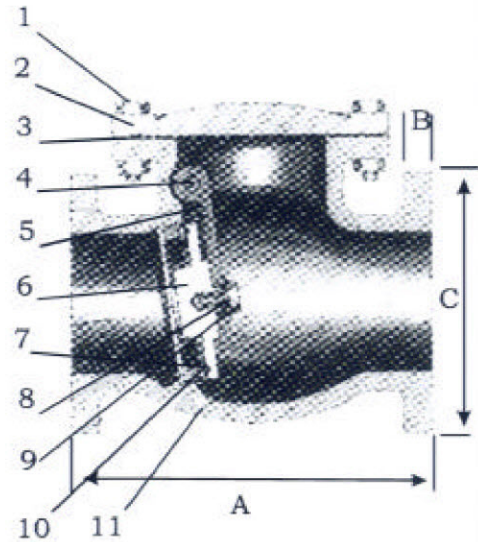

* All Iron Trim, Fig: 128--28

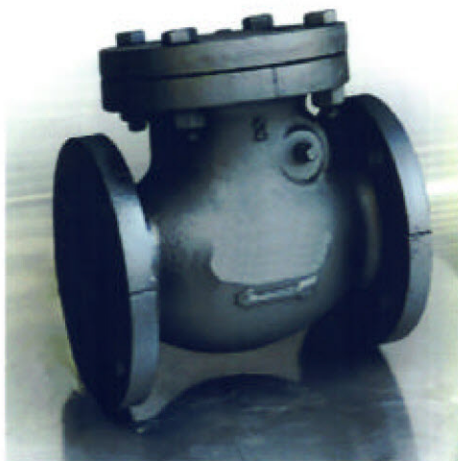

| Nominal Size | Dimensions | | | Approx. Weight |
|--------------|------------|---------|---------|----------------|
| | A | B | C | |
| 2" | 8" | 5/8" | 6" | 30 |
| 2.5" | 8 1/2" | 11/16" | 7" | 46 |
| 3" | 9 1/2" | 3/4" | 7 1/2" | 50 |
| 4" | 11 1/2" | 15/16" | 9" | 90 |
| 5" | 13" | 15/16" | 10" | 112 |
| 6" | 14" | 1" | 11" | 154 |
| 8" | 19 1/2" | 1 1/8" | 13 1/2" | 260 |
| 10" | 24 1/2" | 1 1/4" | 16" | 427 |
| 12" | 27 1/2" | 1 1/4" | 19" | 629 |
| 14" | 31" | 1 3/8" | 21" | 748 |
| 16" | 36" | 1 7/16" | 23 1/2" | 1122 |
| 18" | 38" | 1 9/16" | 25" | 1432 |

**Valves can be supplied with outside weight and lever