

# STEAMCO

Fig. 256-ANG

## Class 250 Iron Body Angle

Bolted Bonnet Angle Pattern Bronze Trim or All Iron Trim

From 2 1/2" to 8"

250 P S I 450 F

500 WOG -20 to 150 F

Applicable Standards: MSS-SP-85, ANSI B16.1, ANSI B16.10

PARTS AND MATERIAL DESCRIPTION			
No.	Part	Material	ASTM Spec.
1	Handwheel Nut	Cast Bronze	ASTM B62
2	Handwheel	Cast Iron	ASTM A126 CL. B
3	Yoke Bushing	Cast Bronze	ASTM B62
4	Bonnet	Cast Iron	ASTM A126 CL. B
5	Stem	Forging Brass	ASTM B16
6	Gland	Cast Iron	ASTM A 126 CL. B
7	Packing	Non-Asbestos	Commercial
8	Body Bolt	Steel	ASTM A307
9	Body Gasket	Non-Asbestos	Commercial
10*	Disk	Cast Bronze	ASTM B62
11*	Seat Ring	Cast Bronze	ASTM B62
12	Body	Cast Iron	ASTM A126 CL. B

\*\* Item 10 and 11 Not Shown

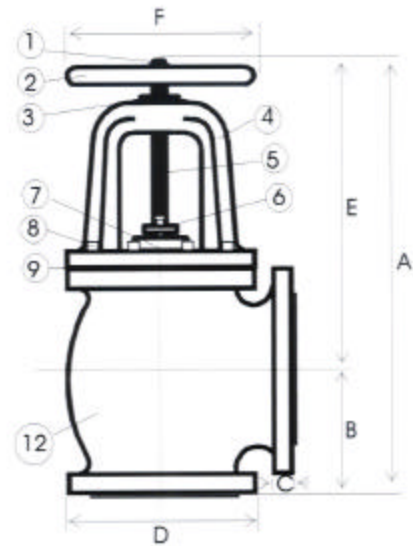

Nominal Size	Dimensions					Aprox. Weight
	A	B	C	D	F	
2 1/2"	18 1/2"	5 3/4"	1"	7 1/2"	8"	75
3"	20 1/2"	6 1/8"	1 1/8"	8 1/8"	10"	113
4"	24 1/2"	7"	1 1/8"	10"	10"	184
6"	31 13/16"	8 3/4"	1 7/16"	12 1/2"	14"	352
8"	33 1/2"	10 1/2"	1 5/8"	15"	16"	480