

Angle Stop Check

Size	D	D1	D2	D3	L	b	D	N-ØC	H	H1*	E	E1*	T
2.5"	2.5	4 15/16	5 7/8	7 1/2	5 3/4	1	1/16	8-Ø7/8	12.75	13.87	11.73	12.85	10
3"	3	5 11/16	6 5/8	8 1/4	6 1/4	1 1/8	1/16	8-Ø7/8	14.65	16	13	14.37	10
4"	4	6 5/16	7 7/8	10	7	1 1/4	1/16	8-Ø7/8	16.3	18	14	15.71	10 4/5
5"	5	8 5/16	9 1/4	11	8	1 3/8	1/16	8-Ø7/8	19.25	21.35	16.57	18.67	14
6"	6	9 11/16	10 5/8	12 1/2	8 3/4	1 7/16	1/16	12-Ø7/8	22.28	24.76	19.45	21.93	17 3/4
8"	8	11 15/16	13	15	10 1/2	1 5/8	1/16	12-Ø1	29.17	32.79	24.64	28.26	20
10"	10	14 1/16	15 1/4	17 1/2	12 1/4	1 7/8	1/16	16-Ø1 1/8					20

* Valve Open

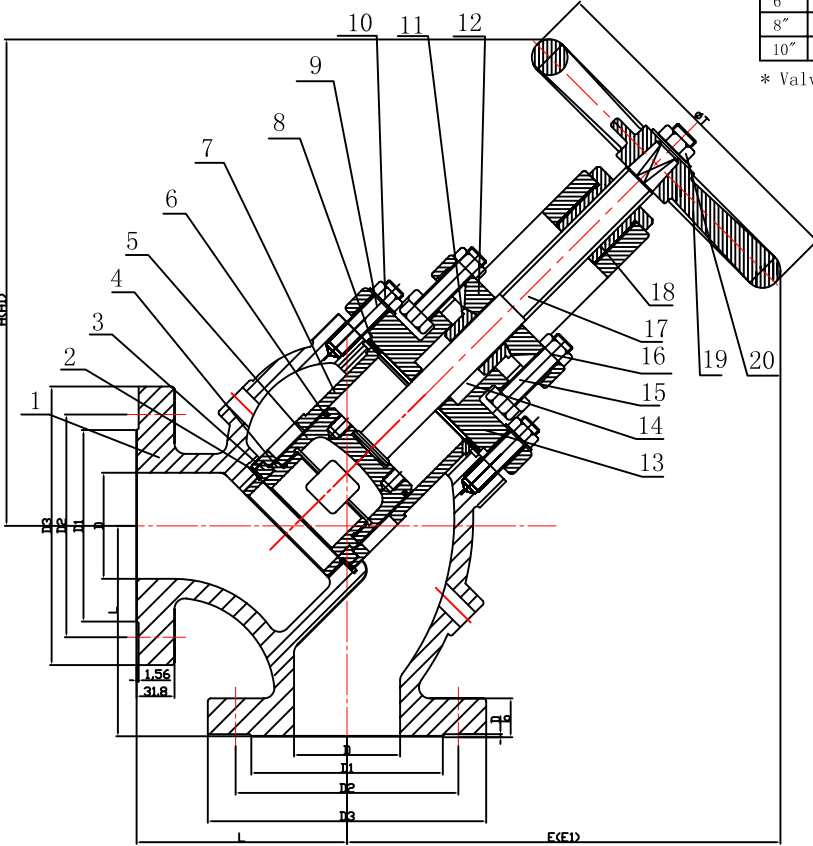

NO.	Part Name	Quantity	Material	Material Standard
1	Body	1	Cast Iron	ASTM A 395
2	Body Seat Gasket	1	Graphite	
3	Body Seat Ring	1	Cast Bronze	ASTM B 62
4	Disc Seal	1	Cast Bronze	ASTM B 62
5	Disc	1	Cast Iron	ASTM A 395
6	Piston Ring	1	Cast Iron	SPRING STEEL
7	Guide Bush	1	Cast Iron	ASTM A 395
8	Body Gasket	1	Graphite	
9	Bolts		Steel	ASTM A 193 B7
10	Nuts		Steel	ASTM A 194 2H
11	Packing Gland	1	Cast Brass	ASTM B 62
12	Gland Follower	1	Cast Iron	ASTM A 395
13	Bonnet	1	Cast Iron	ASTM A 395
14	Packing		Graphite	
15	Bolts		Steel	ASTM A 193 B7
16	Nuts		Steel	ASTM A 194 2H
17	Stem	1	SS410	
18	Stem Nut	1	Cast Brass	ASTM B62
19	Handwheel	1	Cast Iron	ASTM A 126 B
20	Nut	1	Steel	ASTM A 194 2H

STEAMCO

Cast Iron Flgd Bolted Bonnet Angle Stop Check
Class 250

STEAMCO 250ANR