

## EFFORTLESS EFFICIENCY

As a standard, three point external adjusting bolts in the cover assure equilibrium to the compression of the stem and in-line seals by imparting a balanced force through a metal thrust washer located under the cover above the formed metal diaphragm. This mechanism provides a multiple seal to atmosphere and a double (downstream & upstream) bidirectional in-line seal.

Independent wrench stops are cast on the cover to limit the stroke at the open and close positions without endangering the integrity of the seal adjustment as in other manufacturers' designs. Parallel flats are machined on the sides of the plug stem providing positive indication of the direction of flow at all times, independent of other position indicators.

Offered as an option on all ANSI/ASME FluoroSeal® valves, and standard on all DIN valves up to DN 150, is the EZ-SEAL® (patent pending) Top Seal and Adjustment System. Featuring a single point adjustment it eliminates the possibility of plug side loading. The EZ-SEAL® (patent pending) also introduces a new industry standard by the incorporation of a Min / Max gauge on the cover, giving a visual indication of the remaining service life of a valve and easing the process of maintenance planning.

## PLEDGE OF QUALITY

All major pressure bearing and/or boundary components (body, plug and cover) of FluoroSeal® valves are fully traceable to mill test certificates ensuring material authenticity. Quality levels are maintained through continuous inspection and manufacturing surveillance of these and all other components. A concerted effort is made to conform to all regulatory authority requirements where and when invoked, in keeping with FluoroSeal Inc.'s pledge of quality first. FluoroSeal® Plug Valves comply with the following standards:

API 598	API 599	ASME B16.5
ASME B16.10	ASME B16.25	ASME B16.34
ASME B16.42	ASTM F1545-97	DIN EN 558-1
DIN EN 1092-1	DIN EN 12266	MSS SP-55
MSS SP-61	ISO/FDI 10497	

## AT A GLANCE

- Bidirectional flow
- Quarter-turn operation
- Non-lubricated
- Self-cleaning on each operation
- 2-way and multiport configurations
- Special service and jacketed designs available
- All casting components traceable to mill test certificates
- Investment cast on all materials for sizes 1/2" – 10" (ANSI/ASME Class 150 lbs)

- Investment cast on all materials for sizes 1/2" – 6" (ANSI/ASME Class 300 lbs)
- Investment cast on all materials for sizes 1/2" – 6" (ANSI/ASME Class 600 lbs)
- Investment cast on all materials for sizes DN 15 – DN 150 (PN 16 – PN 40)
- Standard heavy-duty gears available on all FluoroSeal® valves

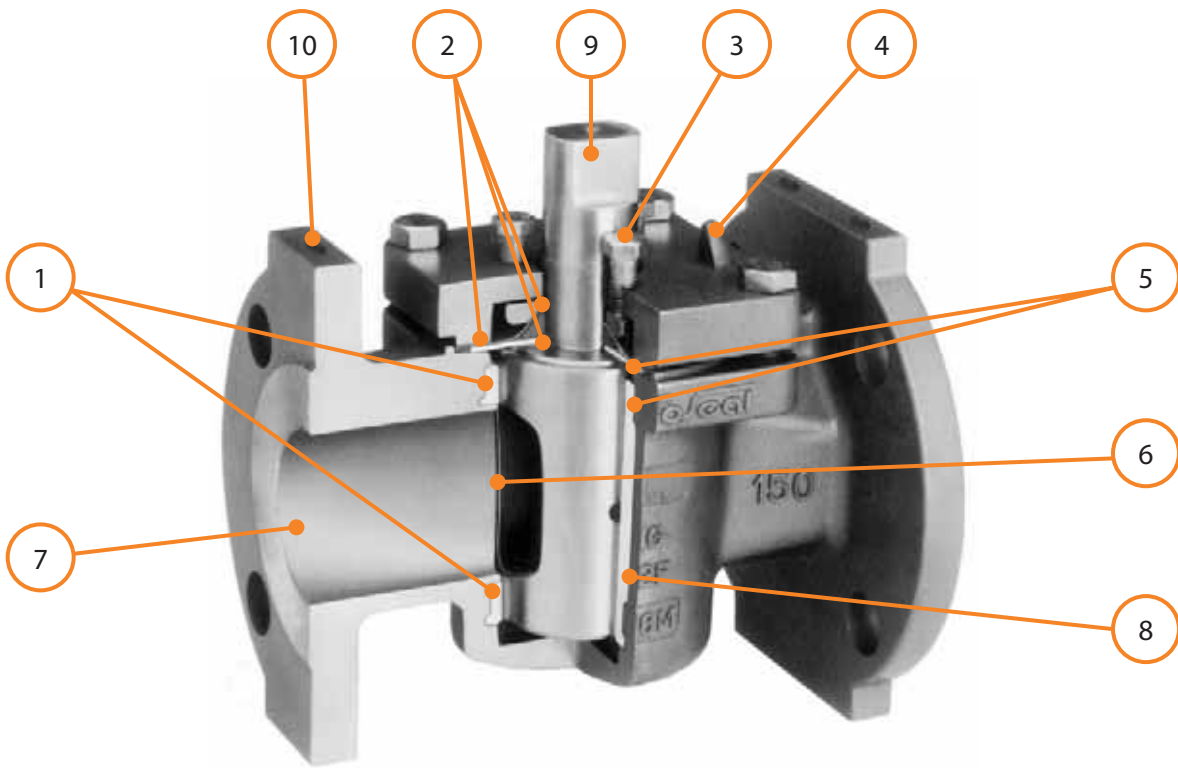

ANSI/ASME Class 150 Lbs FluoroSeal® Plug Valve Cut-Away

DESIGN FEATURES SUMMARY

1. Bidirectional in-line bubble-tight seal independent of line pressure
2. Multiple external bubble-tight seals independent of line pressure
3. Direct mechanical three-point adjustment independent of line pressure
4. Independent travel stops
5. Full encapsulation and retention of all leading edges of PTFE sleeve and top seal components
6. Full lip at port openings protects PTFE sleeve
7. Contoured waterway ensures minimum flow turbulence characteristic
8. No body cavities to entrap flow media
9. Positive flow direction indication
10. Drilled and tapped flange mounting pads independent of cover and top seal assembly

PLUG-ANSI-DIN-R002-2009



ANSI/ASME Class 150 Lbs FluoroSeal® Plug Valve with Wrench

**MATERIALS OF CONSTRUCTION**

Body and Plug <sup>1</sup>	As Specified
Cover <sup>2</sup>	Carbon Steel or 304 SS
Cover Bolts <sup>2</sup>	Carbon Steel or 304 SS
Adjusting Bolts	304 SS
Thrust Washer	304 SS
Metal Diaphragm <sup>3</sup>	304 SS, MONEL®
Delta Ring	PTFE Fluorocarbon
Diaphragm	PTFE Fluorocarbon
Sleeve <sup>4</sup>	PTFE Fluorocarbon
Wrench Operator <sup>5</sup>	Carbon Steel
Wrench Bolt <sup>5</sup>	Steel
Gear Assembly	Heavy Duty Cast Carbon Steel Housing
Gear Adaptor <sup>5</sup>	Hi-Strength Steel
Gear Mounting Bracket	304 SS
Mounting Bracket Bolts <sup>5</sup>	Steel

1. See BODY & PLUGS MATERIAL TABLE for material selections.
2. Cover and bolt materials of standard valves will be supplied in accordance with the following table:

SPECIFIED BODY	COVER	ANSI/ASME COVER BOLT	DIN COVER BOLT
Ductile Iron	Carbon Steel	ASTM A193 Gr. B7	DIN EN 10269
Carbon Steel	Carbon Steel	ASTM A193 Gr. B7	DIN EN 10269
All Other Materials	CF8	ASTM A193 Gr. B8	DIN EN 10269

Covers can be delivered in the same material as body if specified at time of order.

3. MONEL® metal diaphragms will be supplied with valves having a MONEL® or nickel trim. All others will be supplied with 304 SS diaphragms.
4. Glass reinforced PTFE (RTFE), PFA Fluorocarbon, GF2P, Hi-Temp, and UHMWPE sleeves are available on special order.
5. 304 SS available on special order.

PLUG-ANSI-DIN-R002-2009